



THE QUIET ONE®

The Quietest Commercial Blender Available

The ultimate blender with unparalleled sound reduction, exceptional beverage blends, and improved speed of service.

Smart Product Design

- Up to 4 times quieter than the competition due to the advanced vibration dampening technology; resulting in quality drinks in a more enjoyable atmosphere
- Magnetically secured floating sound enclosure is dramatically easier to clean and disassemble. No screws to damage the enclosure
- 6 programmes buttons with 34 optimised programme for easier, consistent blending
- Advance® container creates faster, smoother pouring and has a longer blade life resulting in time and cost savings along with improved customer experience
- Air management and powerful ≈ 3 peak output HP motor reduces noise, improves reliability and reduces down time



Creamy fruit smoothies

Product Specifications

The Quiet One®

Item Number: On-Counter: 50031
In-Counter: 51024

Motor: ≈3 peak output horsepower motor

Electrical: 220 – 240 V, 50/60 Hz, 1300 – 1500 W

Pack: Includes The Quiet One® with 1.4 L high-impact, clear/stackable Advance® container complete with Advance blade assembly and lid, and removable compact enclosure.

Net Weight: 9.1 kg, (12.7 kg with box)

Dimensions:

On-Counter: 45.7 x 21.6 x 27.2 cm (H x W x D)
Height with lid open: 62.2 cm

In-Counter: 41.9 x 21.6 x 27.2 cm (H x W x D)
Height with lid open: 58.4 cm
Depth below counter: 3.0 cm

Warranty: Please contact your authorised Vitamix distributor for warranty information.

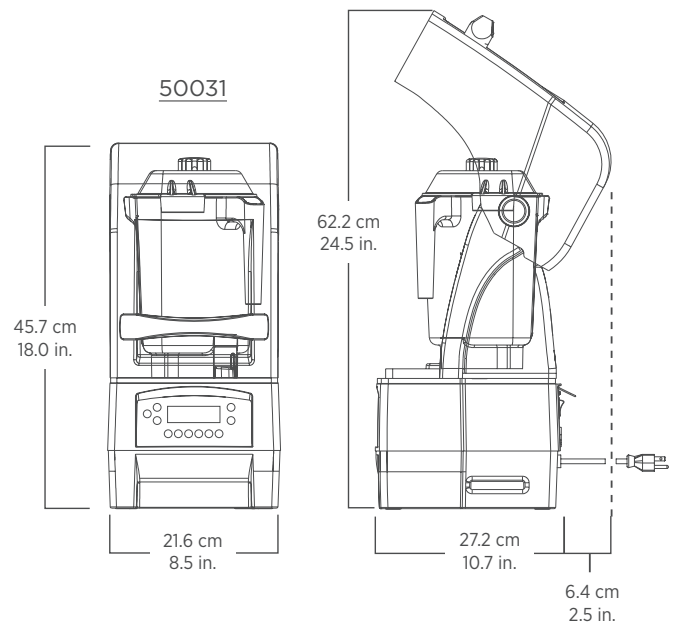

Also Available

Additional containers, complete with blade assembly and lid.

Item Number: 15978: Advance container 1.4 L

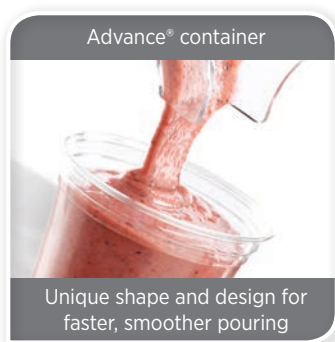
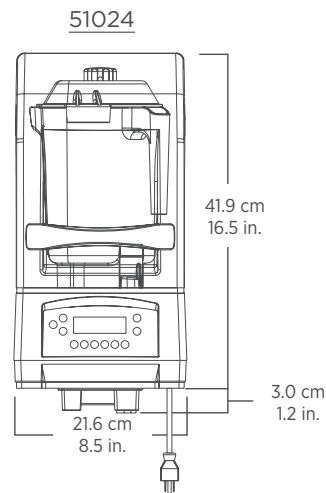

Where applicable:



Contact Information

U.S.A.:

Phone: 800.437.4654
Fax: 440.235.9670
Email: commercial@vitamix.com

vitamix.com

For more information, contact your local foodservice distributor.

Outside of U.S.A.:

Phone: +1.440.782.2450
Fax: +1.440.782.2220
Email: international@vitamix.com